

Full Sweep 15 PSI Boost

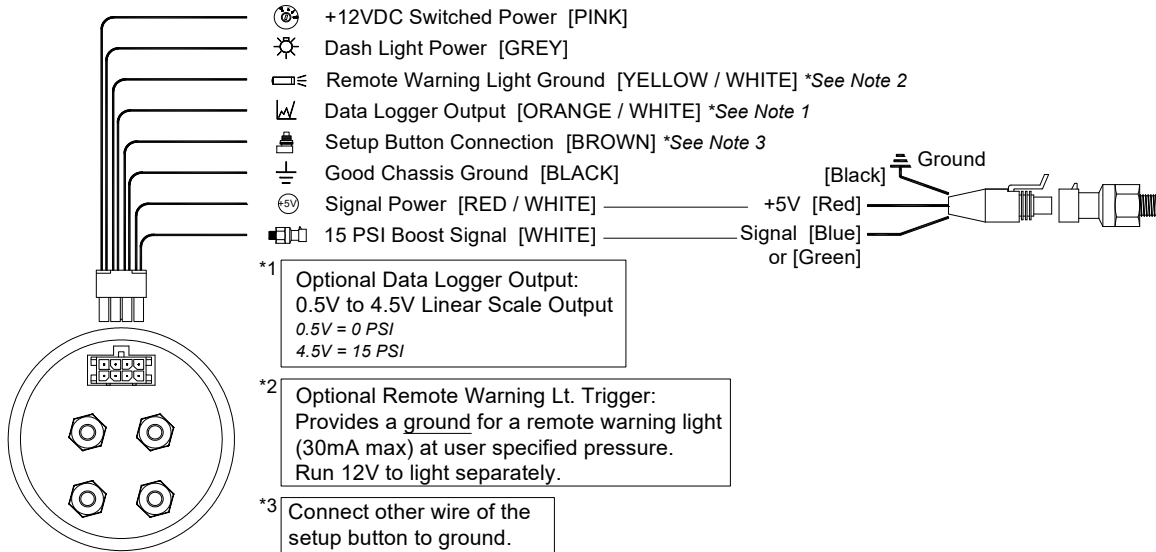

To Set Backlight Color (cool white / warm white):

1. Start with power off.
2. Press and hold pushbutton.
3. While pressing pushbutton, apply power to the gauge (starting vehicle not necessary).
4. Release pushbutton once power is applied.
5. The pointer will indicate 7.5 PSI.
6. Tap the pushbutton to move the pointer to 0 PSI.
7. With the pointer indicating 0 PSI, press and hold the pushbutton until the pointer moves to 3.5 PSI or 11.5 PSI.
8. 3.5 PSI represents the “cool white” lighting option and 11.5 PSI represents the “warm white” lighting option. Tap the pushbutton to move the pointer between 3.5 PSI and 11.5 PSI.
9. When the pointer is indicating the desired lighting option, press and hold the pushbutton until the pointer returns to 0 PSI. Turn off power to save the changes.

To Set Warning Light Trigger Point:

1. Start with power off.
2. Press and hold pushbutton.
3. While pressing pushbutton, apply power to the gauge (starting vehicle not necessary).
4. Release pushbutton once power is applied.
5. The pointer will indicate 7.5 PSI.
6. Tap the pushbutton twice to move the pointer to 0 PSI and back to 7.5 PSI again.
7. Press and hold the pushbutton (with the pointer at 7.5 PSI) until the pointer moves to indicate the warning light trigger point.
8. Press and hold the pushbutton to change the trigger pressure shown. The first time the pushbutton is pressed and held, the pressure shown will increase. The second time the pushbutton is pressed and held, the pressure shown will decrease. The pressure shown will alternate between increasing and decreasing each time the pushbutton is pressed.
9. If the set trigger pressure is set below 7.5 PSI, the warning light will come on when the pressure is below the trigger pressure. If the set trigger pressure is set above 7.5 PSI, the warning light will come on when the pressure is above the trigger pressure.
10. Once the desired trigger point is shown, wait 10 seconds without pushing the pushbutton in order to save the setting. The pointer will return to 0 PSI. Turn off power to save the changes.

Important: Turn power OFF to the gauge after making changes in order to save those changes